

Lever type Long Stylus



MODEL 29/38 | LONG STYLUS



302L

AGD TYPE | LONG STYLUS C (1⁵/₃₃"

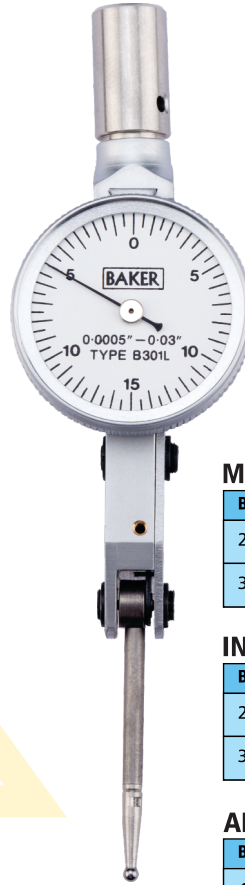

B301L

METRIC

Bezel dia.	Type	Reading	Range	Graduation
29 mm	302L	0.01mm	0.8mm	0-40-0
	302AL			
38 mm	306L			
	306AL			

INCH

Bezel dia.	Type	Reading	Range	Graduation
29 mm	301L	0.0005"	0.03"	0-15-0
	301AL			
38 mm	305L			
	305AL			

ANSI (AGD)

Bezel dia.	Type	Reading	Range	Graduation
1 ⁵ / ₃₃ "	B301L	0.0005"	0.03"	0-15-0
	B301AL			
1 ¹ / ₂ "	B305L			
	B305AL			

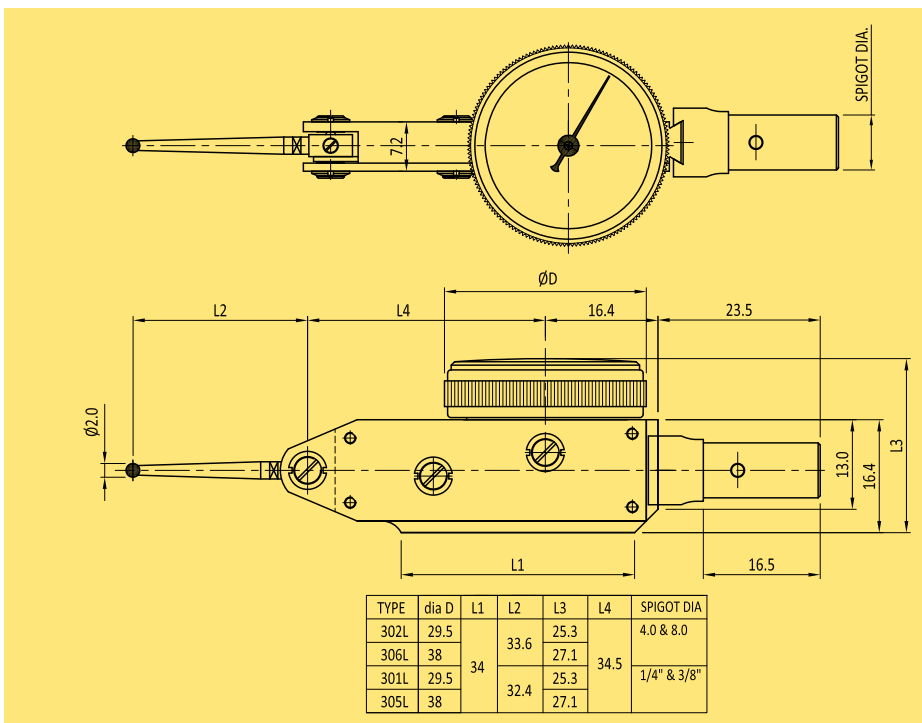

FEATURES

- Every gauge carries a calibration certificate giving actual values
- Auto reversal mechanism
- Fitted with jewels and Swiss miniature ball bearings for smoother operation
- Rigid brass body for increased rigidity
- Robust and highly sensitive gauge suitable for workshop use
- Metric Gauges conform to IS 11498 and for the European market to DIN 2270
- Inch Gauges conform to ASME B89.1.10M
- Special dial Gauges for OEMs also manufactured on request
- Complete spares and after sales service available
- Integral dovetail offers flexibility and rigidity for mounting of the gauge
- Metric & Inch gauges are supplied with 2mm tungsten carbide ball stylus and 8 mm spigot assembly as standard supply
- No additional accessories are offered when suffix A is added to the type number