

# Granite Comparator Stands

**Luthra**  
००००००००००



# Granite Comparator Stands



Dial comparator stands are designed for comparison measurement of size using a dial indicator, as it is most reliable instrument. We manufacture one of the finest quality of granite and cast iron comparator stands which are widely known for its quality and workmanship.

**We have well equipped NABL accredited calibration laboratory.**

- Granite comparator stands are made from selected black granite.
- Precision lapped for feather finish and fine accuracy.
- Corrosion resistant and non magnetic base.
- Heavy duty vertical column and gauging bracket.
- Accepts all electronic and standard gauges.
- Calibration certificate is provided with each comparator stand.

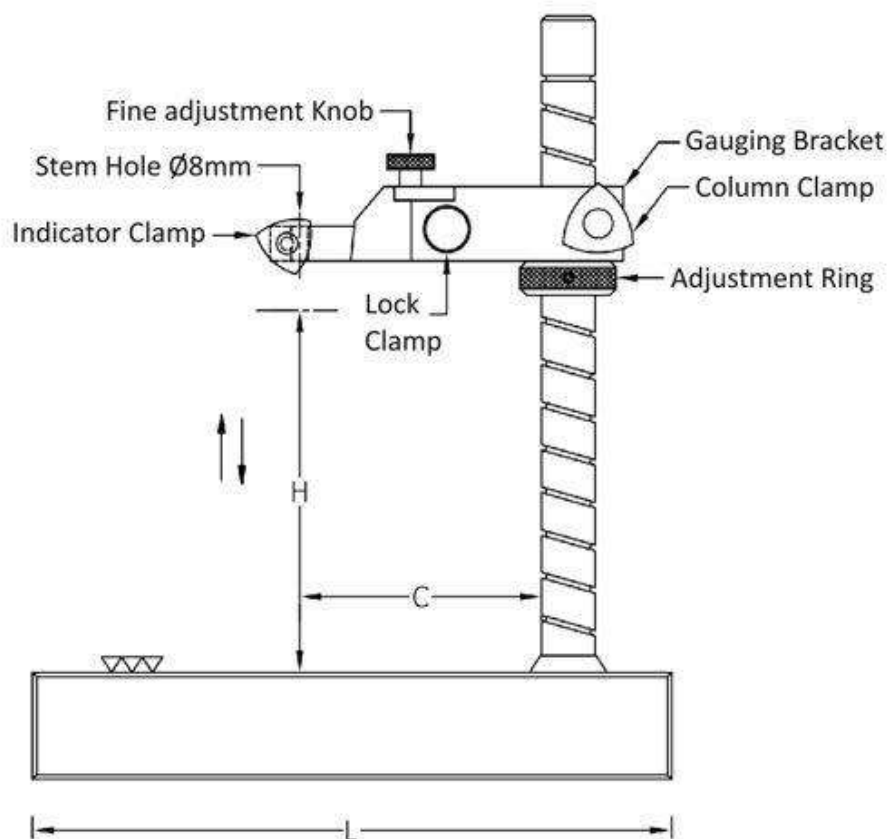

## Fine Adjustment Model

- Granite base, Gauging bracket and Vertical column can be customized



## Granite Comparator Stands

**Luthra**

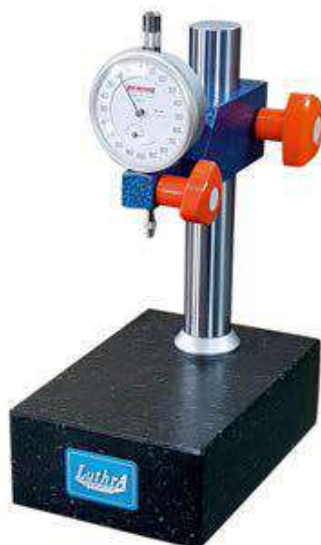

LGS - 1



LGS - 2



LGS - 3

Model	Base Size mm	Base Type	Flatness Microns $\mu$ m	Gauging Bracket	Measuring Height (H) mm	Cross Arm (C) mm	Coulnn Dia mm	Net Weight Kgs
LGS-1	150 x 100	Plain	3	Centre	100	55	25	4.00
LGS-2	150 x 100	Plain	3	Fine Adjustment	100	55	25	4.00
LGS-3	150 x 100	Serrated	3	Centre	100	55	25	4.00



LGS - 4



LGS - 5



LGS - 6



LGS - 7

Model	Base Size mm	Base Type	Flatness Microns $\mu\text{m}$	Gauging Bracket	Measuring Height (H) mm	Cross Arm (C) mm	Column Dia mm	Net Weight Kgs
LGS-4	150 x 100	Serrated	3	Fine Adjustment	100	55	25	4.00
LGS-5	150 x 150	Plain	3	Centre	100	55	25	4.00
LGS-6	150 x 150	Plain	3	Fine Adjustment	100	55	25	4.00
LGS-7	150 x 150	Serrated	3	Fine Adjustment	100	55	25	4.00

# Granite Comparator Stands



LGS - 8



LGS - 9



LGS - 10

Model	Base Size mm	Base Type	Flatness Microns $\mu$ m	Gauging Bracket	Measuring Height (H) mm	Cross Arm (C) mm	Coulnn Dia mm	Net Weight Kgs
LGS-8	250 x 150	Plain	3	Centre	150	85	25	8.00
LGS-9	250 x 150	Plain	3	Fine Adjustment	150	85	25	8.50
LGS-10	250 x 150	Plain	3	Eccentric	150	100	25	9.00





LGS - 11



LGS - 12



LGS - 13

Model	Base Size mm	Base Type	Flatness Microns $\mu$ m	Gauging Bracket	Measuring Height (H) mm	Cross Arm (C) mm	Column Dia mm	Net Weight Kgs
LGS-11	250 x 150	Serrated	3	Centre	150	85	25	8.00
LGS-12	250 x 150	Serrated	3	Fine Adjustment	150	85	25	8.50
LGS-13	250 x 150	Serrated	3	Eccentric	150	100	25	9.00

## Granite Comparator Stands

**Luthra**



LGS - 14



LGS - 15



LGS - 16

Model	Base Size mm	Base Type	Flatness Microns $\mu$ m	Gauging Bracket	Measuring Height (H) mm	Cross Arm (C) mm	Couln Dia mm	Net Weight Kgs
LGS-14	300 x 200	Plain	3.5	Centre	200	115	28	12.00
LGS-15	300 x 200	Plain	3.5	Fine Adjustment	200	110	28	12.50
LGS-16	300 x 200	Plain	3.5	Eccentric	200	200	28	13.00



LGS - 17



LGS - 18



LGS - 19

Model	Base Size mm	Base Type	Flatness Microns $\mu$ m	Gauging Bracket	Measuring Height (H) mm	Cross Arm (C) mm	Couln Dia mm	Net Weight Kgs
LGS-17	300 x 200	Serrated	3.50	Centre	200	115	28	12.00
LGS-18	300 x 200	Serrated	3.50	Fine Adjustment	200	110	28	12.50
LGS-19	300 x 200	Serrated	3.50	Eccentric	200	200	28	13.00



# Granite Comparator Stands



LGS - 20



LGS - 21



LGS - 22

Model	Base Size mm	Base Type	Flatness Microns $\mu$ m	Gauging Bracket	Measuring Height (H) mm	Cross Arm (C) mm	Column Dia mm	Net Weight Kgs
LGS-20	300 x 300	Plain	4	Centre	250	115	28	17.50
LGS-21	300 x 300	Plain	4	Fine Adjustment	250	110	28	18.00
LGS-22	300 x 300	Plain	4	Eccentric	250	200	28	18.50



LGS - 23



LGS - 24



LGS - 25



LGS - 26

Model	Base Size mm	Base Type	Flatness Microns $\mu\text{m}$	Gauging Bracket	Measuring Height (H) mm	Cross Arm (C) mm	Column Dia mm	Net Weight Kgs
LGS-23	300 x 300	Serrated	4.0	Centre	250	115	28	17.5
LGS-24	300 x 300	Serrated	4.0	Fine Adjustment	250	110	28	18.0
LGS-25	300 x 300	Serrated	4.0	Eccentric	250	200	28	18.5
LGS-26	300 x 300	Plain	4.0	Double Eccentric	250	200	28	22.0

# Granite Comparator Stands



LGS - 27



LGS - 28



LGS - 29



LGS - 30

Model	Base Size mm	Base Type	Flatness Microns $\mu$ m	Gauging Bracket	Measuring Height (H) mm	Cross Arm (C) mm	Coulnn Dia mm	Net Weight Kgs
LGS-27	300 x 300	Plain	4.0	Universal Arm	250	200	28	16.00
LGS-28	400 x 400	Plain	4.5	Centre	300	150	35	35.00
LGS-29	400 x 400	Plain	4.5	Fine Adjustment	300	150	35	35.00
LGS-30	400 x 400	Plain	4.5	Eccentric	300	250	35	35.00